

National 5 Maths

Arcs and Sectors: Arc Length

SQA past paper and specimen paper questions and answers by topic

SQA material is copyright © Scottish Qualifications Authority and has been reproduced by kind permission of SQA.

This resource is free to distribute and use on a non-commercial basis.

Visit [Maths.scot](https://www.maths.scot) for full worked solutions to each of these questions.





The pendulum of a clock swings along an arc of a circle, centre O.

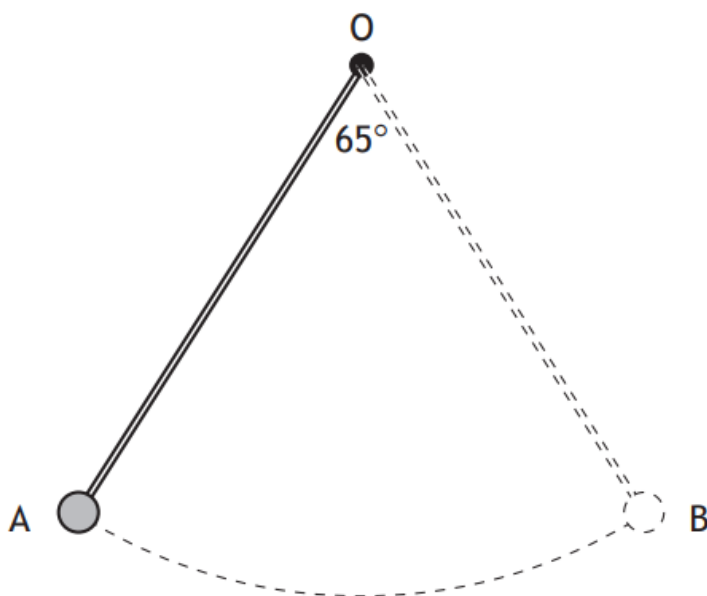

The pendulum swings through an angle of 65° , travelling from A to B.

The length of the arc AB is 28.4 centimetres.

Calculate the length of the pendulum.

4

Answer:

25.0 cm



The diagram below shows part of a circle, centre O.

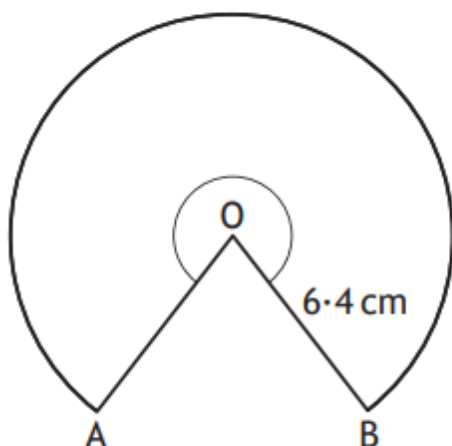

The radius of the circle is 6.4 centimetres.

Major arc AB has length 31.5 centimetres.

Calculate the size of the reflex angle AOB.

3

Answer:

282.0°

The diagram below shows a sector of a circle, centre C.

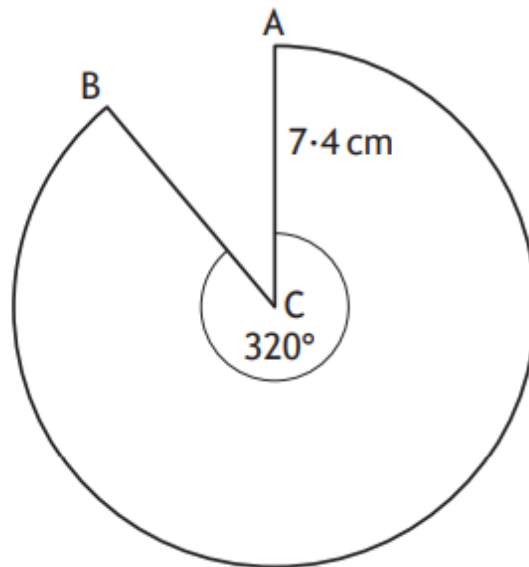

The radius of the circle is 7.4 centimetres.

Calculate the length of the major arc AB.

3

Answer:

41.32 cm

The diagram below shows a sector of a circle, centre C.

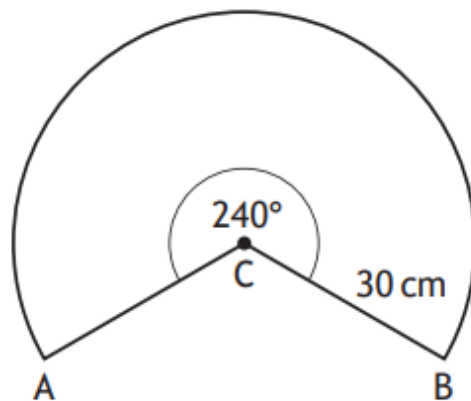

The radius of the circle is 30 centimetres.

Calculate the length of the major arc AB.

Take $\pi = 3.14$.

3

Answer:

125.6 cm

An attraction at a theme park has a carriage attached to an arm.



The arm swings from A to B along the arc of a circle, centre C, as shown in the diagram below.

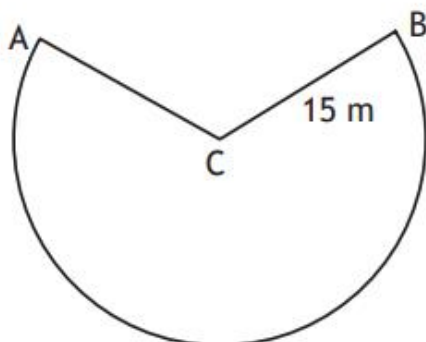

- The length of the arm, CB, is 15 metres.
- The length of the major arc, AB, is 69.4 metres.

Calculate the size of the reflex angle ACB.

3

Answer:

265.1°

The diagram shows part of a football pitch.

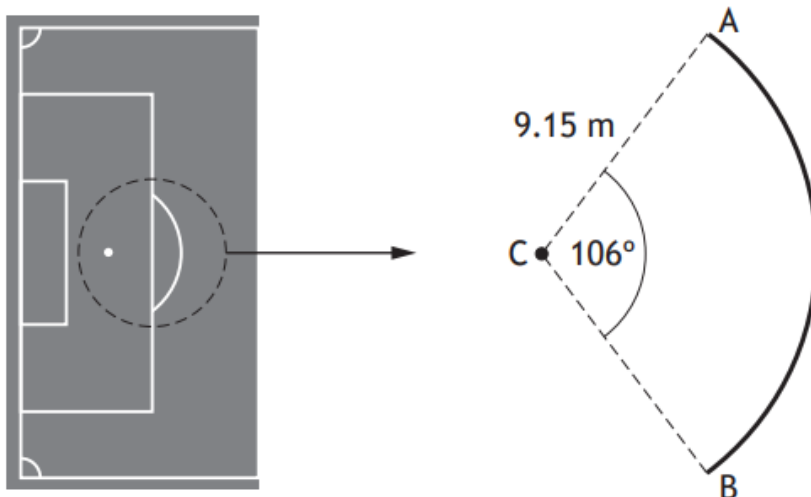

The penalty spot is marked at point C.

AB is an arc of a circle, centre C, radius 9.15 metres.

Calculate the length of the arc AB.

3

Answer:

16.9 metres

The diagram shows a sector of a circle, centre C.

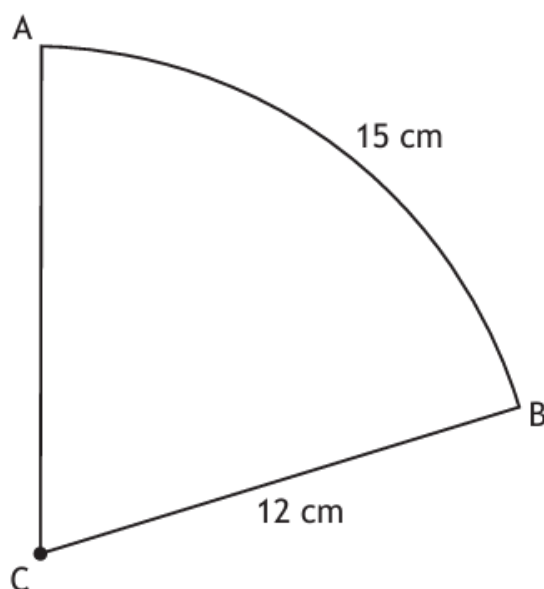

The radius of the circle is 12 centimetres.

The length of arc AB is 15 centimetres.

Calculate the area of the sector.

3

Answer:

90 cm²